

9700



9700
with backlit
high topper

Triton's 9700 Series ATMs are the perfect low-cost solution for today's retail ATM market. These sleek, new machines offer legendary Triton reliability and a host of standard features that are upgrades on other ATMs—all at an unbeatable price. That's what makes the 9700 the new workhorse of the industry.

You'll have to look long and hard to find a comparable ATM with standard features like an electronic lock, a color LCD screen, a 33.6K modem, and 2MB of memory, EPP (Encrypting PIN Pad) and Triple DES software. Or one that

The new workhorse of the ATM market.

gives you as much flexibility where you need it most, cash capacity. As evidenced by the 9700's multiple mechanism options and ability to hold up to four cassettes.

The 9700 further proves our commitment to compliance by adhering to all existing and proposed Americans with Disabilities Act (ADA) regulations, including private audio transactions. It's another standard feature that means more access for your customers and less worries for you.

9700 IN DETAIL



The new workhorse of the ATM market.

FEATURES:

- One to four cassettes
- Multiple dispenser options
- 5.7" (145 mm) color LCD transaction screen
- 60 mm thermal printer
- 2MB memory
- 33.6k modem
- Dip style card reader or optional EMV smart card reader
- Footprint Dimensions
 - 16.8" wide (427 mm)
 - * 19.8" deep (503 mm)
 - 54.4" high (1390 mm)
 - without topper
 - 64.5" high (1638 mm)
 - with topper
 - 77.4" high (1966 mm)
 - with high topper
- Weight 172 lbs. (78 kg)
 - weight varies with options
- Americans with Disabilities Act (ADA) compliant
- Encrypting PIN Pad (EPP) to comply with international encryption standards, Triple DES compliant
- Audio transactions

* The footprint depth may vary with different cassette options

- for the visually impaired
- UL 291 Business Hours Service cabinet or optional UL 291 Level 1 safe
- Advertising revenue potential:
 - Decal and signage
 - Couponing
 - Transaction screen
 - Full-motion video option
- Dial-up, satellite, and TCP/IP communications options
- Electronic lock standard, MAS Hamilton lock optional
- Triton Connect™ compatible
- Two Back-lit graphic topper options: topper and high topper

OPERATING SPECS:

- Temperature
 - 10° - 40° C / 50° - 104° F
- Relative Humidity
 - 20%-80% Non-condensing
- Power Consumption
 - 2.0A @ 115 VAC at 60 Hz
 - 1.0A @ 230 VAC at 50 Hz

9700 with backlit topper



ATM INSTALLATION SPACE REQUIREMENTS FOR ADA COMPLIANCE

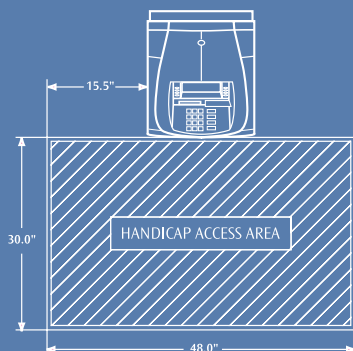

The dimensions shown comply with US Federal ADA guidelines. For installation within the US, be sure to check state and local guidelines for complete compliance. For non-USA installations, check regulations for the country in which the machine will be installed.

For additional information on any of the ATMs in Triton's line-up, please visit our web site at www.imsatm.com.

IMS • 336 South Fulton Avenue • Mount Vernon, NY 10553
 Phone: 914-699-4000 • Toll free: USA & Canada 1-800-808-8445
www.imsatm.com • email: info@imsatm.com

