

RT2000



RT2000

For many high-traffic locations, there has simply never been a cost-effective way to provide customers with access to a 24-hour walk-up ATM. Most of the big, traditional ATMs are too costly and complicated to even consider. The extremely reliable and

Finally, get more out of your high-traffic location with a cost efficient, 24-hour, through-the-wall ATM..

affordable RT2000 gives merchants a low-cost, easy to service alternative to more expensive through-the-wall ATMs.

It's no surprise this innovation comes from Triton. Triton customers know that our hallmark affordability is the result of decades of engineering and innovation. The RT2000's high-performance is partly due to the Triton custom-engineered dispensing mechanisms. Triton's self-calibrating dispenser mechanisms are designed to dispense 250,000 notes with no preventive maintenance.

The Triton RT2000 is easy to install. It's easy to maintain. And most of all, its low cost and reliability means your high-traffic ATM location can finally become a high-profit ATM location. Finally, a through-the-wall ATM built by the experts in retail ATMs.

RT2000 IN DETAIL

A cost-efficient, 24-hour through-the-wall ATM designed with the merchant in mind.



FEATURES:

- Single and Multi-cassette
- 5.7" mono display or optional 6.5" color display
- 80mm thermal printer with presenter
- 64 MB RAM standard
- Microsoft Windows® CE.net operating system supports file formats for adding custom logos and ads
- Intel XScale® 32-bit processor
- One USB device port
- Four USB master ports
- Two PCMCIA card slots (one occupied by modem)
- Five serial ports
- Dial-up 56k baud internationally certified modem and TCP/IP communications standard, wireless optional
- Dip-style card reader, optional EMV smart card or motorized card reader
- Americans with Disabilities Act (ADA) compliant
- Audio transactions for the visually impaired

- Encrypting PIN Pad (EPP) to comply with all international encryption standards, Triple DES compliant
- UL 291 Business Hours Service Cabinet
- Manual lock standard, optional electronic or Kaba® Mas Cencon lock
- Multi-lingual capabilities
- LED lead-through indicators
- Advertising revenue potential: Decal and signage
Coupons
Transaction screen
- Dimensions:
Depth 29.7" (754.4 mm)
Width 22.4" Sleeve (569 mm)
20.5" Vault (520.7 mm)
Height 63.6" (1615.4 mm)
Weight 275 lbs (125 kg)

OPERATING SPECS:

- Temperature Vault/Electronics 10° - 40° C / 50° - 104° F
- Relative Humidity 20% - 80% non-condensing
- Power consumption
2.0 A @ 115 VAC at 60 Hz
1.0 A @ 230 VAC at 50 Hz



RT2000

ATM INSTALLATION SPACE REQUIREMENTS FOR ADA COMPLIANCE

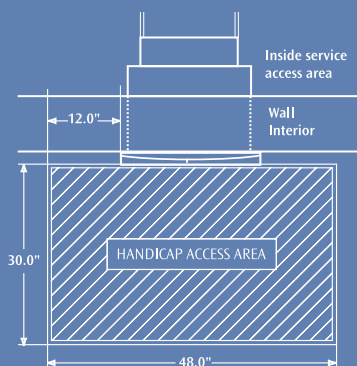

The dimensions shown comply with US Federal ADA guidelines. For installation within the US, be sure to check state and local guidelines for complete compliance. For non-USA installations, check regulations for the country in which the machine will be installed.

**specifications subject to change without notice*

For additional information on any of the ATMs in Triton's line-up, please visit our website at www.imsatm.com.

IMS • 336 South Fulton Avenue • Mount Vernon, NY 10553
Phone: 914-699-4000 • Toll free: USA & Canada 1-800-808-8445
www.imsatm.com • email: info@imsatm.com

Triton® WHERE MONEY COMES FROM.™
A DOVER COMPANY

Triton is a registered trademark of Triton Systems of Delaware, Inc. Triton is an operating company of Dover Industries, Inc., a subsidiary of Dover Corporation (NYSE-DOV). © Delaware Capital Formation, Inc., 2004. All Rights Reserved. DOVER and DOVER logo are registered trademarks of Delaware Capital Formation, Inc., a wholly-owned subsidiary of Dover Corporation.

07203-00035